

TP9 Electronic Central Heating Controller



Programmable Room Thermostat plus Domestic Hot Water Timer, for the Control of Domestic Central Heating

INSTALLATION INSTRUCTIONS

Technical Specifications

Temperature Range	: 5-30°C or 16-30°C
Power Supply	: 220Vac/240Vac, 50/60Hz
Switching Action	: 2 x SPDT, type 1B
Switch Rating	: 220/240Vac, 50/60 Hz, 3(1)A
Timing Accuracy	: ± 1 min/month
Power Reserve	: Minimum 24 hours
Enclosure Rating	: IP30
Max. Ambient Temp	: 45°C
Control Pollution Situation	: Pollution degree 2
Designed to meet	: BS EN60730-2-9

Overall Dimensions	
- Controller	: Width 136mm, Height 88mm, Depth 32mm.
- Sensor	: Width 60mm, Height 45mm, Depth 21mm.
Software classification	: Class A
Rated impulse voltage	: 2.5kV
Ball pressure test	: 75°C

The unit must be installed by a competent electrician and the installation should conform to IEE Wiring Regulations. The supply to this unit should be wired via a full disconnect in accordance with BS EN60730-1, i.e. one which provides air gaps of at least 3mm in both poles of the mains, and incorporates a 3 amp. fuse. It is strongly recommended that solid conductors be used.

Installation and Wiring

- Select the desired fixing position for the heating controller.
- When fixing the wallplate remember the connections are at the top and the vertical centre line of the unit is at the position shown C/L, (which is at the right hand edge of the terminal 4 recess.)
- Fix the wallplate to the wall or flush mounted box as required.
- Surface cables can only enter from below the unit. If mounted on a flush mounted box, cables can enter from the rear through the aperture in the wallplate.
- Whilst the unit does not require an Earth connection, two terminals are provided on the wallplate for Earth continuity purposes.
- Locate and fix the Remote Sensor, this should be as per room thermostat i.e. 1.5m above floor, away from draughts and extraneous heat gains. Remote Sensor wiring should be in 1mm² Mains Voltage Cable (not flexible cord). Sensor cable must not be run parallel to mains cable in order to avoid pick-up.
- Overleaf are typical wiring diagrams which together with the information above should enable all the services to be connected correctly.
- Ensure all dust and debris are cleared from the area.
- The unit may now be set for either 24 hour or 5/2 day operation. It is supplied ready for 5/2 day operation, and in the unlinked PUMPED primaries condition. To convert it to 24 hour operation move the switches 2 and 3 on the back of the unit to the 24 HR position. To operate in the linked GRAVITY condition, for instance in a system having gravity primaries with no control of gravity circuit flow, move switch 1 to the GRAVITY position.
- Locate the module on the two locating lugs on the top of the wallplate and hinge downwards to fully engage the fixing screws in the slots at the bottom of the module. Tighten the screws.
- If the unit is disconnected from the mains supply, either intentionally or due to a power-cut, the life-long integral battery will retain both time-of-day, day, and the programmed times for fifteen days. During this period the display will appear normal, except for the blinking battery symbol, with the clock keeping time. On the sixteenth day of continuous interruption of power, the clock will stop and the display will become blank, except for the colon which will be on continuously. However, the programmed times and temperatures will be remembered. When the power is restored

(after more than fifteen days) the unit must be started by pressing any key. The clock will restart at 12:00PM (MO), and all that need be done by the user is to set up the time-of-day, (and day-of-week if the unit is 5/2 day mode).

- IMPORTANT:** To remove unit from wall, isolate power supply. Slacken the two screws at the underside of the module and ease the bottom of the module away from the wall to disengage from the wallplate. Lift the module off the two locating lugs on the top of the wallplate.

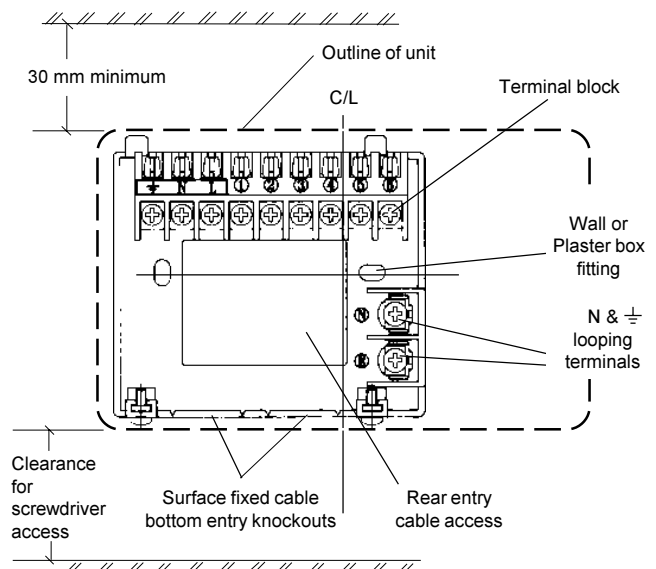

Mains Supply			HW	CH	HW	CH	Remote
Via 3A Fuse			OFF	OFF	ON	ON	Sensor
Earth	N	L	1	2	3	4	5 6

Typical Wiring Diagrams

Given below are typical wiring diagrams for various types of systems, and whilst every attempt has been made to ensure the accuracy of this information it is recommended that the specific information relating to the ancillary controls is obtained from the manufacturers concerned.

NOTES: The TP9 does not have voltage free contacts, therefore it is NOT suitable for connection to low voltage equipment.

Remote Sensor to be wired with 1mm 2 core double insulated cable only. Cable length should not exceed 50 metres.

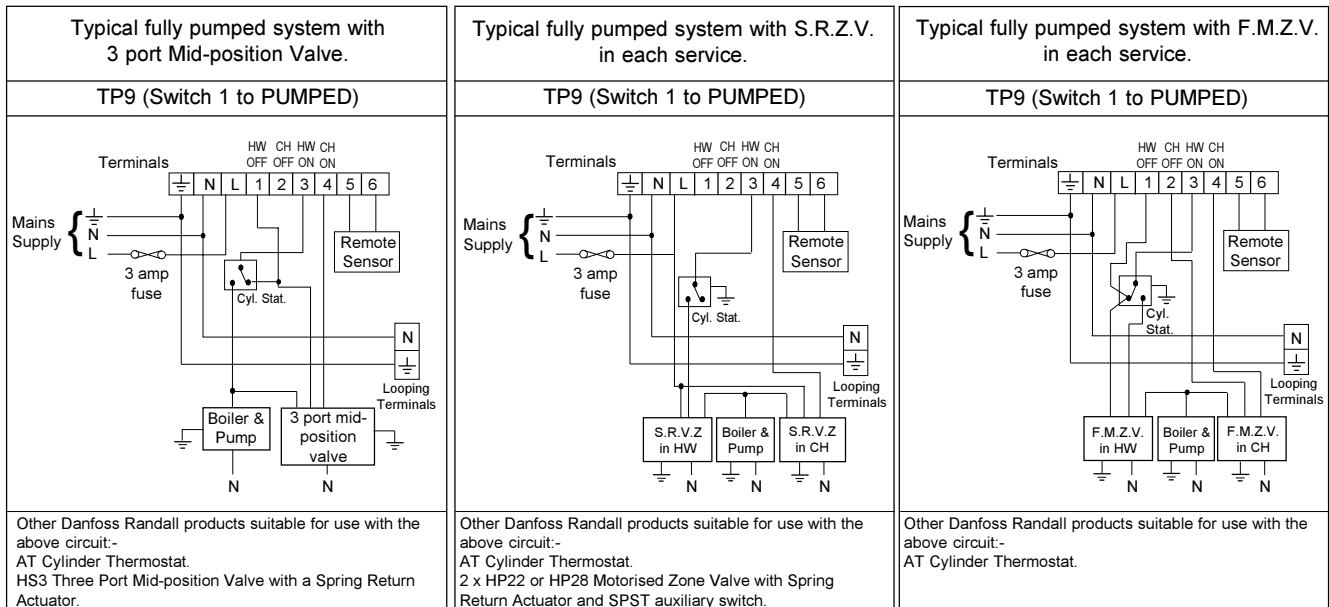
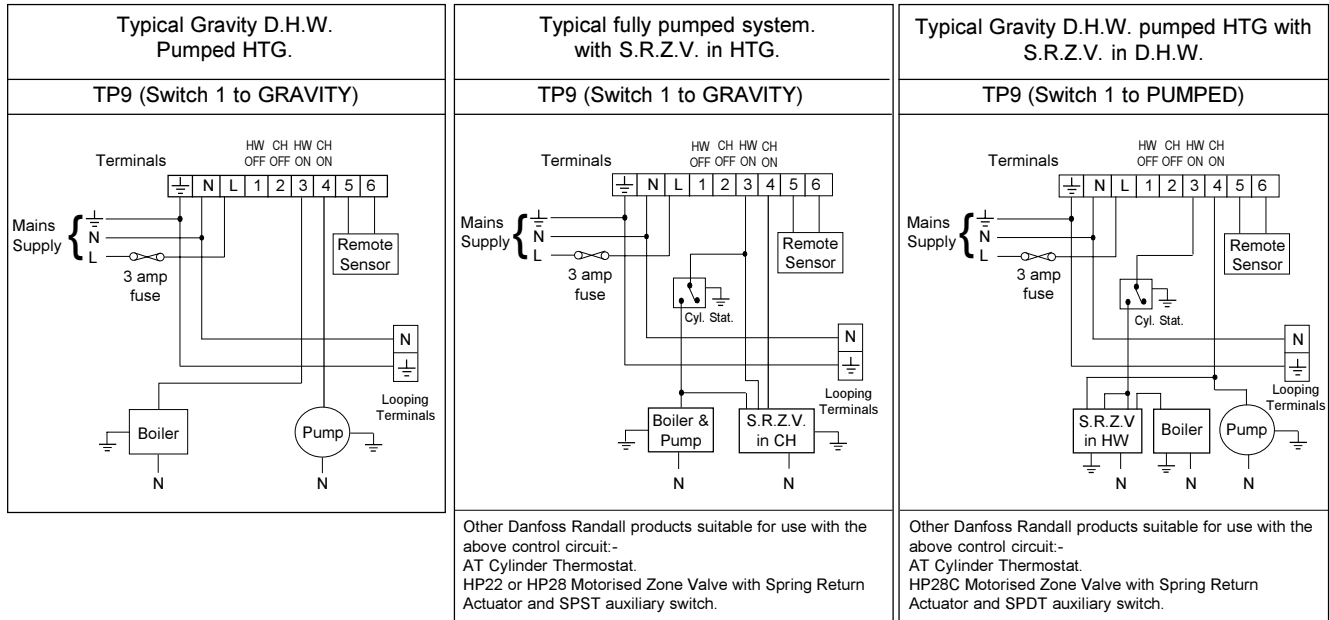

S.R.Z.V. = spring return zone valve. F.M.Z.V. = fully motorised zone valve. Ensure Earth continuity throughout, where Earth is required.

NOTE: Danfoss Randall manufacture a complete range of domestic heating controls including timeswitches and programmers, room and cylinder thermostats, thermostatic radiator valves, motorised valves and boiler efficiency controls; as well as a comprehensive range of commercial time controls and valves. Ask for our full colour Product Selection Guide.

This product complies with the following EC Directives:
Electro-Magnetic Compatibility Directive.
 (EMC) (89\336\EEC), (92\31\EEC)
Low Voltage Directive.
 (LVD) (73\23\EEC), (93\68\EEC)



TP9 Electronic Central Heating Controller



Programmable Room Thermostat plus Domestic Hot Water Timer

USER INSTRUCTIONS

General Description

The TP9 can have a room temperature setting range of either 5°C to 30°C or 16°C to 30°C. Switch 4 on the back of the module is used to choose which range. In all display diagrams the 5°C to 30°C range is used.

The TP9 will control your Central Heating and Domestic Hot Water system in any one of three ways:

1. Automatically adjust room temperature up to six times a day providing comfort with economy, and switch on the hot water heating circuit twice a day.
2. Switch off the water and control the heating to provide a constant low room temperature while the home is empty for extended periods. The display will appear as in Fig. 2. (N.B. When the unit switches the CH on, the HW will also switch on if the unit has been set for linked GRAVITY operation).
3. Operate as a 2 ON/2 OFF Hot Water timeswitch during the summer, or other times when Central Heating is not needed. The display will appear as in Fig. 3. (If the room temperature falls below the low setting displayed, the heating will switch ON). If the minimum temperature you can select is 16°C and you do not want the heating to switch ON at all whilst operating in this mode, you should ask your installer to fit an extra switch to the CH output. He can get the information he needs to do this from our Technical Services Department.

Switching from one type of operation to the next is achieved by pressing both temperature adjustment buttons (▲, ▼) together.

While operating as 1 or 3 above, the +1HR ON button can be pressed at any time to heat the Hot Water for an extra hour.

First-Time Installation

When the unit is first removed from its packaging the display will, most probably, just show two dots (the colon).

THIS IS NOT A FAULT, but a battery saving feature.

Once fitted in accordance with the Installation Instructions supplied and the mains electricity is switched on, the unit should be activated by pressing any button and then RESET.

Reset

Reset the unit by pressing and holding down the four buttons; TEMPERATURE up (▲) and down (▼), minus (-) and plus (+) all at the same time, for at least two seconds, until the display becomes completely blank. Release the buttons, and the unit will begin automatically with the display similar to Fig. 1. i.e. 12:00PM with the colon blinking, 16°C, and the day (MO) shown if the unit is set for 5/2 day operation.

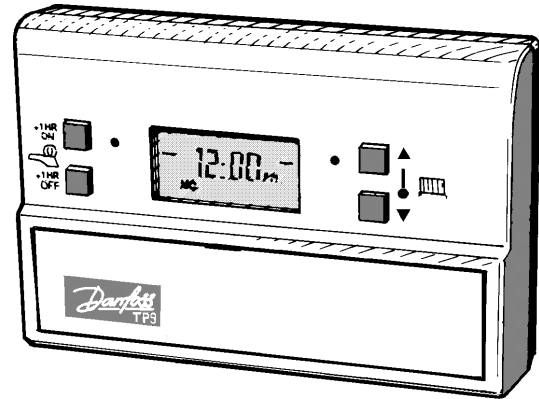

Fig. 1.

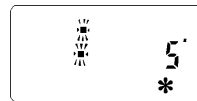

Fig. 2.
Constant Low Temperature Mode.



Fig. 3.
Hot Water Only Mode,
(Central Heating will switch on if room temperature falls below 5°C.)

Automatic Operation

While the colon is blinking the clock is running and the unit will control your Central Heating (CH) and Domestic Hot Water (HW) in accordance with the set programme. The unit incorporates a Factory Pre-set Programme which is detailed in table 1 overleaf.

Setting the Clock Checking and, if required, changing the Factory Pre-set Programme.

To set the clock to the correct time and check the factory pre-set programme, or change it to suit your lifestyle, use the PROG, minus (-) and plus (+) buttons.

Starting from the RUN mode (with the colon blinking); each press of the PROG buttons steps through the checking and setting sequence, which is listed in table 2 overleaf.

Follow this sequence to check/change first the time-of-day, then the times and temperatures, and finally the hot water ON/OFF times. If you change any or all of the time and/or temperature settings, record the new ones on the space provided in table 1.

You may reinstate the Factory pre-set times and temperatures at any time by performing a RESET as described earlier.

This product complies with the following EC Directives:
Electro-Magnetic Compatibility Directive.
(EMC) (89\336\EEC), (92\31\EEC)
Low Voltage Directive.
(LVD) (73\23\EEC), (93\68\EEC)



Table 1. Factory pre-set programme, and user record.

Central heating control times and temperatures.								
Setting No:	24 hour control (same each day)				5/2 day control (Sat/Sun)			
	Pre-set		User's		Pre-set		User's	
	Time	Temp	Time	Temp	Time	Temp	Time	Temp
1	6:30AM	20°			7:00AM	20°C		
2	8:30AM	16°			10:00AM	16°C		
3	12:30AM	19°			12:00PM	19°C		
4	1:30PM	16°			2:00PM	16°C		
5	5:30PM	21°			5:00PM	21°C		
6	10:30PM	16°			10:30PM	16°C		

When running normally the unit will control the heating system at the chosen temperatures.

To over-ride the programmed temperature use the (▲ or ▼) buttons. An up or down arrow will appear in the display as a reminder that the programme is over-riden. The selected temperature will last until the next programmed change.

When the Central Heating is ON, a flame symbol appears in the display and the red CH indicator illuminates.

When the Hot Water is ON, a tap symbol appears in the display and the HW indicator illuminates.

When the WATER +1 HR ON button is pressed, a O symbol appears in the display. This will extend an existing ON period by an hour, or switch ON for just one hour if the Hot Water is OFF.

If the unit is disconnected from the mains supply, either intentionally or due to a power-cut, the life-long integral battery will retain both time-of-day, day, and the programmed times for fifteen days. During this period the display will appear normal except for the blinking battery symbol, with the clock keeping time. On the sixteenth day of continuous interruption of power, the clock will stop and the display will become blank, except for the colon which will be on continuously. However, the programmed times and temperatures will be remembered. When the power is restored (after more than fifteen days) the unit must be started by pressing any key. The clock will restart at 12:00PM (MO), and all that need be done by the user is to set up the time-of-day, (and day-of-week if the unit is 5/2 day mode).

Domestic Hot Water Times			
Setting	Function	Pre-set	User's
A	On	6:30AM	
b	Off	8:30AM	
C	On	5:30PM	
d	Off	10:30PM	

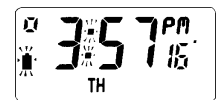

Setting Sequence using PROG Button

Setting		Starting from RUN with the colon blinking.	Setting	The next four settings are for the Hot Water On/Off times.	
24hr	5/2 day			24hr	5/2day
1	1	Colon stops blinking. SET TIME using — and + buttons. Next press starts clock.	8 to 11	15 to 18	Setting A.. Hot Water On Setting B. Hot Water Off Setting C. Hot Water On Setting D. Hot Water Off
	2	SET DAY using using — and + buttons. (only if in 5/2 day mode)	12	19	Return to RUN mode.
2	3	Control setting 1. Use — and + to set time. Use ▲ and ▼ to set temperature.	LIMITS OF ADJUSTMENT FOR TIME SETTINGS. Time settings 1 and A can be at any time of the day or night, but would normally be in the morning. Each of the time settings 2 to 6 and b to d can at any time between the preceding setting and 1:59AM. Time settings 2 to 5 and b and C can be set later than the next setting, but doing this changes the next setting as well e.g. changing setting 2, in table 1 above, to 3:00PM would also change settings 3 and 4 to 3:00PM. This feature prevents times being set out of sequence. If you wish to return to the pre-set programme, reset the unit as described overleaf.		
3 to 7	4 to 8	Control settings 2 to 6: (repeat above)			
	9 to 14	Control settings 1 to 6 for Sat and Sun. (only if in 5/2 day mode)			



Danfoss Randall can accept no responsibility for possible errors in catalogues, brochures and other printed material. Danfoss Randall reserves the right to alter its products without notice. This also applies to products already on order provided that such alterations can be made subsequent changes being necessary in specifications already agreed.

Danfoss Randall Limited,

Amphill Road,
Bedford MK42 9ER.
Telephone: (01234) 364621 Fax: (01234) 219705
Email: danfossrandall@danfoss.com
Website: www.danfoss-randall.co.uk